

FLOWATCH® SILENCE DT20 **siccom**

The perfect combination of silence, performance, reliability and simplicity.
The new standard in condensate pumps!

Ref: DE20PMCD700

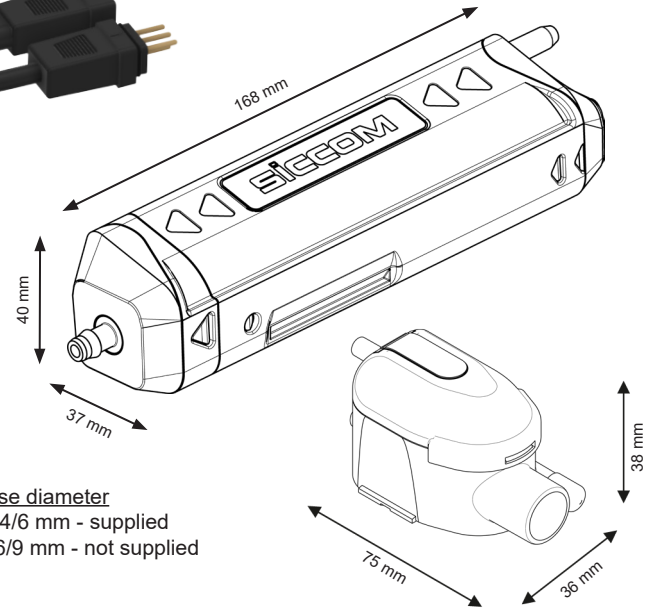

Hose diameter
Suction : 4/6 mm - supplied
Discharge : 6/9 mm - not supplied



SPECIFICATIONS

Flowrate max	20 l/h
Suction head max	2 m
Discharge head max	10 m
Electrical power	3W
Voltage	100-240V 50/60Hz
Alarm	NC
Noise level*	
Protection rating	IP64
Operating cycle**	100%
Power / alarm cable	1.6 m
Dimensions	168 x 37 x 40 mm / 75 x 36 x 38 mm

* Notation from 1 wave (≤ 20 dBA) to 6 waves (> 45 dBA)

** The pump is able to run 100% of the time if necessary.

BENEFITS

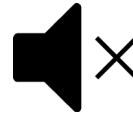

Extreme silence

An unrivalled user experience. No disturbance, even in the bedroom.

DT20 TECHNO

New technology

Ultra-low power consumption, unrivalled silence, exceptional reliability... Tested and approved!



IP64 protection

Protected against water splashes and dust.



Plug & Play quick connectors

Make installation and maintenance easier.

3W

Very low power consumption

Only 3W power consumption, during operation only!



Stop siphoning included

Allows to avoid all risk of negative discharge and to secure the pump functioning over time.

FLOWRATE

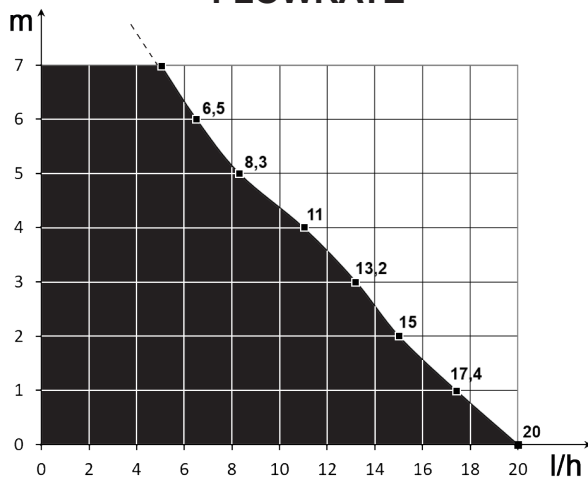

CONTENTS

Pump - Reservoir with air-vent tube - Power / alarm cable - Stop Siphoning - Reservoir stand - Double-sided adhesives - Inlet tube - Suction tube 1.8 m - 3 clamps

